

# KR-series - Underbody cylinder



KRM 223-8-2460-354-G0351-HC

Item no.  
Tipping weight

R68847354  
30 ton

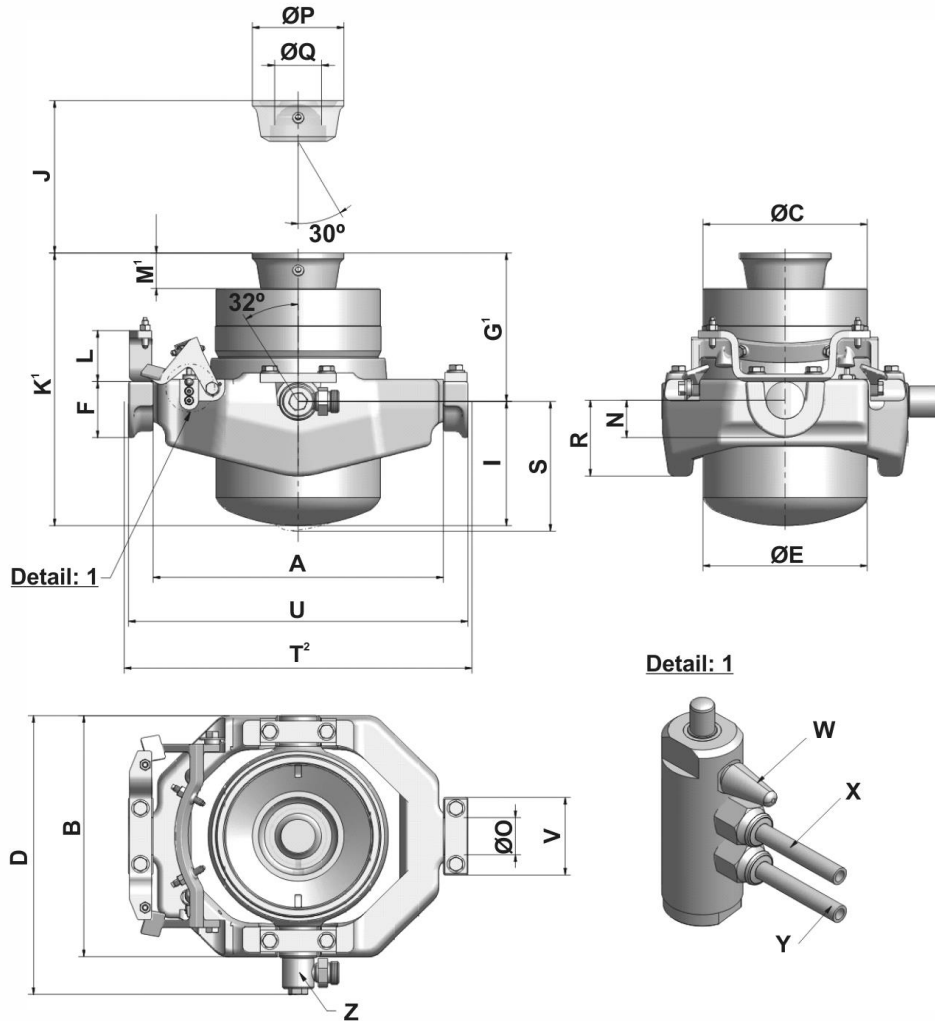

A	459	mm
B	388	mm
C	260	mm
D	455	mm
E	260	mm
F	90	mm
G <sup>1</sup>	351	mm
H		
I	200	mm
J	2460	mm
K <sup>1</sup>	551	mm
L	82	mm
M <sup>1</sup>	77	mm
N	60	mm
O	60	mm
P	145	mm
Q	75	mm
R	122	mm
S	209	mm
T <sup>2</sup>	538	mm
U	537	mm
V	125	mm
W	Exhaust	
X	To tipping valve "TIP" (connection for pneumatic line 6x1)	
Y	From air control (connection for pneumatic line 6x1)	
Z	Swivelling pressure connection for tube Ø25 mm	

<sup>1</sup> Including 20 [-5; +30] mm pull out  
<sup>2</sup> Crossbeam distance 538 [-0.5; +1] mm

3D model is available on request

## Specifications

Max. working pressure	300 bar	Max. pump flow (with KO)	65 L/min	Cradle type	Cradle type 4
Total weight	248 kg	Max. pump flow (without KO)	46 L/min	Knock off type	Pneumatic
Working volume	44 L	Resulting tipping time (with KO)	40 sec		
Total volume	47 L	Resulting tipping time (without KO)	57 sec		
Max. cyl. load (start tipping)	300 kN	Allowable lowering time	41 sec		

KO: Hyva knock off

Extension	1	2	3	4	5	6	7	8	9	Total
Effective diameter [mm]	223	193	167	145	125	107	090	074		2460
Stroke <sup>1</sup> [mm]	299	320	323	313	310	301	292	304		

## Technical notes

- This cylinder is a lifting device only. • It should not be used as a structural member and should not be subjected to side loads. • Tipping valve must have a pressure relief at the cylinder port set not higher than max. working pressure. • Maximum angle of rotation during operation is 32 deg. • Working pressure depends on the application, but must never exceed the maximum working pressure stated. • Working temperature range is between -40°C and +80°C. • Max. duration of extension is 0.5 hours (excluded hard chromed stages). • Cylinder is painted black (RAL9005) with a thickness conforming to the 480 hours neutral salt spray test as per ISO 9227 (ISO10289, rating 9).

## Related documentation

Bracket options: 015BRA16

Mounting instructions: CYL-0024

Oil specifications: OIL-0011

For detailed tipping calculations please refer to: <https://tipper.hyva.com>

# KR-series - Underbody cylinder



KRM 223-8-2460-354-G0351-HC

R68847354

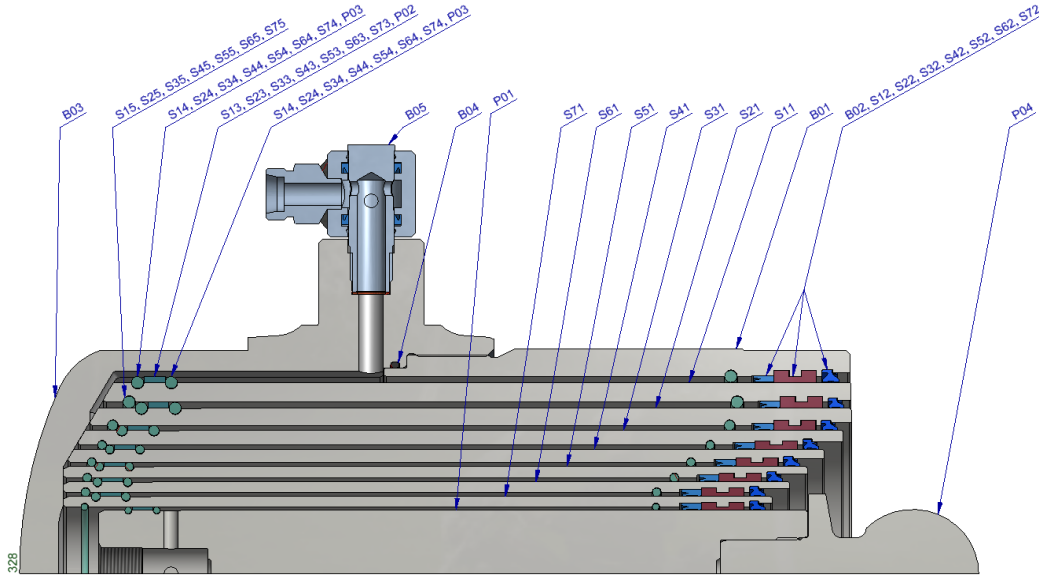

Pos.	Part no.	Description	Qty.
P01	76024031	PISTON 074-403-HC	1
P02	75018551 K	SLIDER 74x12	1
P03	G00322452 K	OUTER STOPRING 74x4	2
P04	75024176 K	SPHERE THREAD Ø75 FL	1

S41	75964301	STAGE 145-430-K73-HC	1
S42	75412145 K	PACKSET 145 KRA/KRM	1
S43	75018438 K	SLIDER 145x12	1
S44	G00322498 K	OUTER STOPRING 145x5	2
S45	G03224921 K	LIFTRING Ø 130 X 5 MB	1

--	--	--	--

S31	75974351	STAGE 167-435-K73-HC	1
S32	75412167 K	PACKSET 167 KRA/KRM	1
S33	75018439 K	SLIDER 167x12	1
S34	G03225091 K	OUTER STOPRING 167x6	2
S35	G03224991 K	LIFTRING Ø 150 X 5 MB	1

S71	75934031	STAGE 090-403-K64-HC	1
S72	75412090 K	PACKSET 090 KRA/KRM	1
S73	75018550 K	SLIDER 90x12	1
S74	G03224655 K	OUTER STOPRING 90x5	2
S75	G03224535 K	LIFTRING Ø 78 X 4 MB	1

S21	75984331	STAGE 193-433-K66-HC	1
S22	75412193 K	PACKSET 193 KRA/KRM	1
S23	75018440 K	SLIDER 193x12	1
S24	G03225233 K	OUTER STOPRING 193x7	2
S25	G03225096 K	LIFTRING Ø 173 X 6 MB	1

S61	75944131	STAGE 107-413-K73-HC	1
S62	75412107 K	PACKSET 107 KRA/KRM	1
S63	75018549 K	SLIDER 107x12	1
S64	G00322477 K	OUTER STOPRING 107x5	2
S65	G00322471 K	LIFTRING Ø 95 X 5 MB	1

S11	75994251	STAGE 223-425-K61-HC	1
S12	75412223 K	PACKSET 223 KRA/KRM	1
S13	75018490 K	SLIDER 223x12	1
S14	G32254975 K	OUTER STOPRING 223x7	2
S15	G00322531 K	LIFTRING Ø 200 X 7 MB	1

S51	75954231	STAGE 125-423-K73-HC	1
S52	75412125 K	PACKSET 125 KRA/KRM	1
S53	75018437 K	SLIDER 125x12	1
S54	G00322489 K	OUTER STOPRING 125x5	2
S55	G00322482 K	LIFTRING Ø 112 X 5 MB	1

B01	75892670	BASE 260-267-K64	1
B02	75412260 K	PACKSET 260 KRA/KRM	1
B03	75410265 K	BASE BOTTOM KRM 260 PIN60 A290	1
B04	G00331007 K	O-RING 242 X 4 70 SHORE	1
B05	75419025 K	COUPLING SET R25	1

## Notes

See 015BRA16 for cradle and bracket spare parts.

## Seal kit complete

75420188	Consists of all packsets with packset grease and O-rings	
----------	--	--

\*The inner stopring is pre-mounted in the grooves on spare stages and pistons. Therefore, when ordering new tubes, it is not required to order stoprings separately.

For repair instructions see: CYL-0034. Serial no. is located on type plate and near type plate support.