

Stage
diameters

110
93
77
61
45

front view cylinder

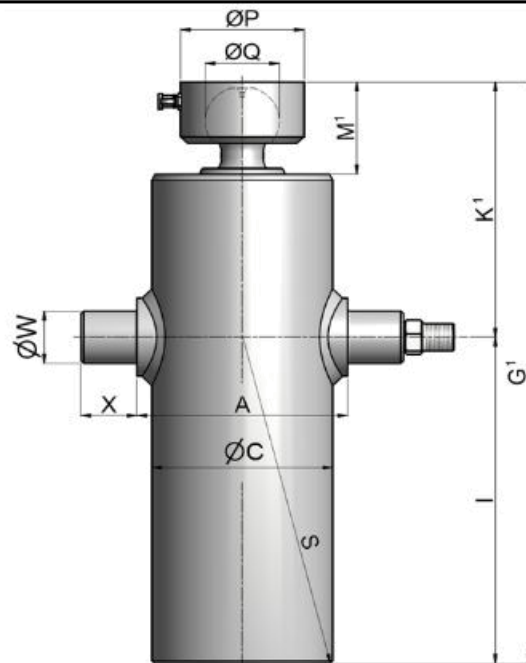

A	150
ØC	130
G'	445
I	276
K'	169
M'	79
ØP	80
ØQ	45
S	284
ØW	40
X	40

¹including 20 mm pull-out [tol. -5; +30 mm]

²cylinder is delivered including oil inlet swivel adapter and cup

specifications

total stroke ¹	1240 mm
dry weight cylinder only	32 kg
total volume	7.1 L
working volume	6.3 L
maximum pressure	190 bar
maximum pump flow	24 l/min
maximum allowable thrust first stage ³	8.0 ton
oil inlet	1/2" BSP