

Stage
diameters

149
129
110
91

front view cylinder

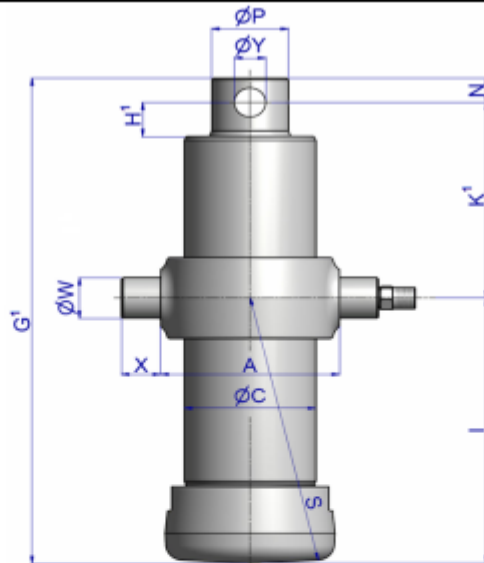

A	205
$\varnothing C$	170
G^1	598
I	347
K^1	221
H^1	62
N	30
$\varnothing P$	88
$\varnothing Y$	35.5
S	357
$\varnothing W$	50
X	45

¹including 20 mm pull-out [tol. -5; +30 mm]

specifications

total stroke ¹	1500 mm
dry weight cylinder only	73 kg
total volume	18.9 L
working volume	17.4 L
maximum pressure	220 bar
maximum pump flow	98 l/min
maximum allowable thrust first stage ²	25.0 ton
oil inlet	3/4" BSP