

Stage  
diameters

191  
169  
149  
129  
110  
91  
72  
53

front view cylinder

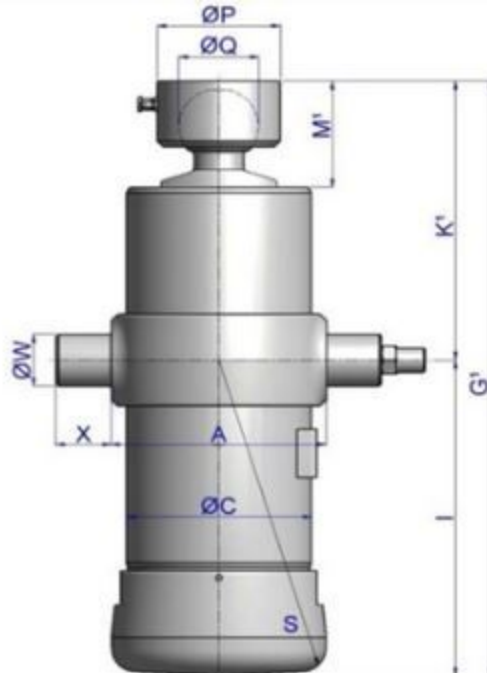

A	245
$\varnothing C$	215
$G'$	543
I	265
$K'$	278
$M'$	114
$\varnothing P$	100
$\varnothing Q$	65
S	286
$\varnothing W$	60
X	45

<sup>1</sup>including 20 mm pull-out [tol. -5; +30 mm]

## specifications

total stroke <sup>1</sup>	2380 mm
dry weight cylinder only	106 kg
total volume	33.5 L
working volume	30.9 L
maximum pressure	220 bar
maximum pump flow	33 l/min
maximum allowable thrust first stage <sup>3</sup>	20.0 ton
oil inlet	3/4" BSP