

Stage
diameters

191
169
149
129
110
91
72

front view cylinder

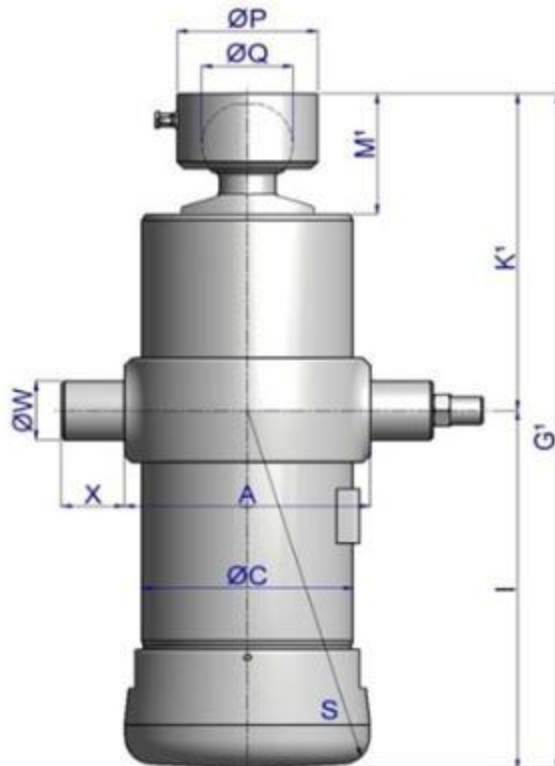

A	245
$\varnothing C$	215
G^1	583
I	305
K^1	278
M^1	114
$\varnothing P$	100
$\varnothing Q$	65
S	323
$\varnothing W$	60
X	45

¹including 20 mm pull-out [tol. -5; +30 mm]

specifications

total stroke ¹	2360 mm
dry weight cylinder only	118 kg
total volume	37.0 L
working volume	34.3 L
maximum pressure	220 bar
maximum pump flow	61 l/min
maximum allowable thrust first stage ³	25.0 ton
oil inlet	3/4" BSP