

Stage diameters
169
149
129
110
91

front view cylinder

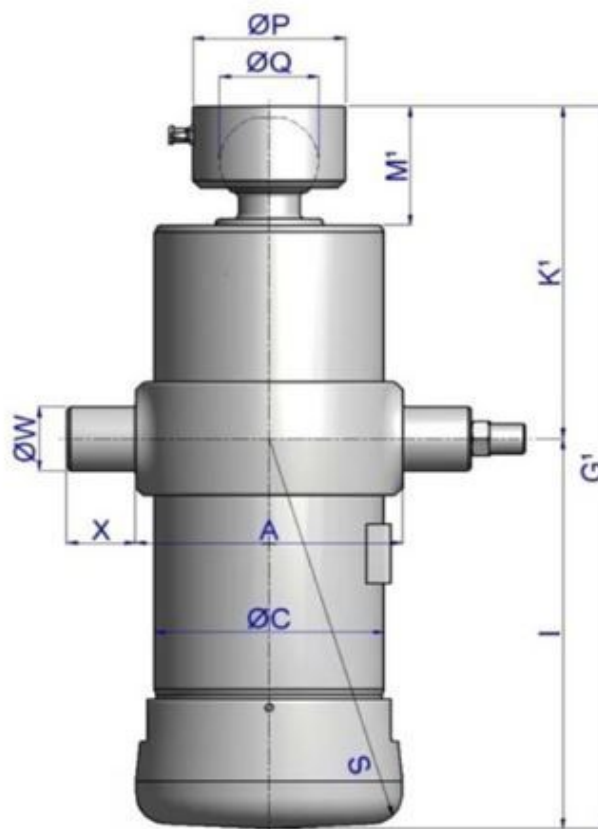

A	230
ØC	192
G ¹	746
I	481
K ¹	265
M ¹	106
ØP	110
ØQ	75
S	490
ØW	50
X	45

¹including 20 mm pull-out [tol. -5; +30 mm]

specifications

total stroke ¹	2480 mm
dry weight cylinder only	115 kg
total volume	37.0 L
working volume	34.2 L
maximum pressure	220 bar
maximum pump flow	98 l/min
maximum allowable thrust first stage ³	25.0 ton
oil inlet	3/4" BSP