

Stage
diameters

149
129
110
91
72
53

front view cylinder

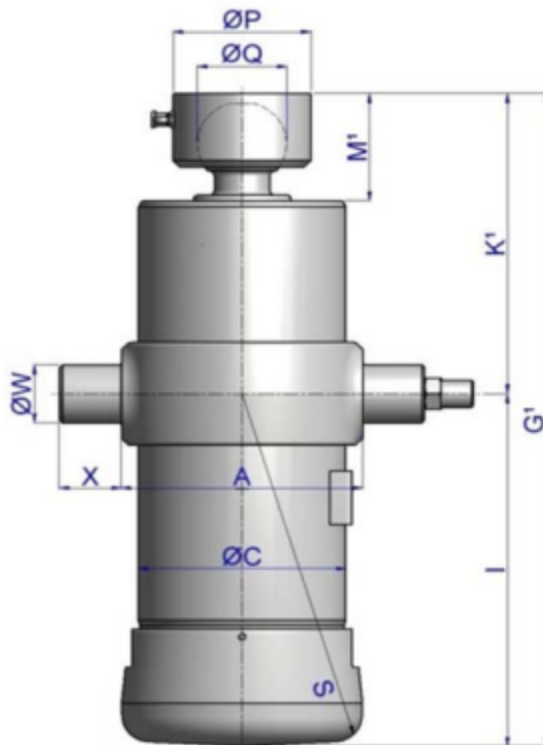

A	205
ØC	170
G¹	512
I	267
K¹	245
M¹	86
ØP	88
ØQ	53
S	280
ØW	50
X	45

¹including 20 mm pull-out [tol. -5; +30 mm]

specifications

total stroke ¹	1780 mm
dry weight cylinder only	73 kg
total volume	17.2 L
working volume	15.7 L
maximum pressure	220 bar
maximum pump flow	33 l/min
maximum allowable thrust first stage ³	15.0 ton
oil inlet	3/4" BSP