

Stage diameters
169
149
129
110
91
72

front view cylinder

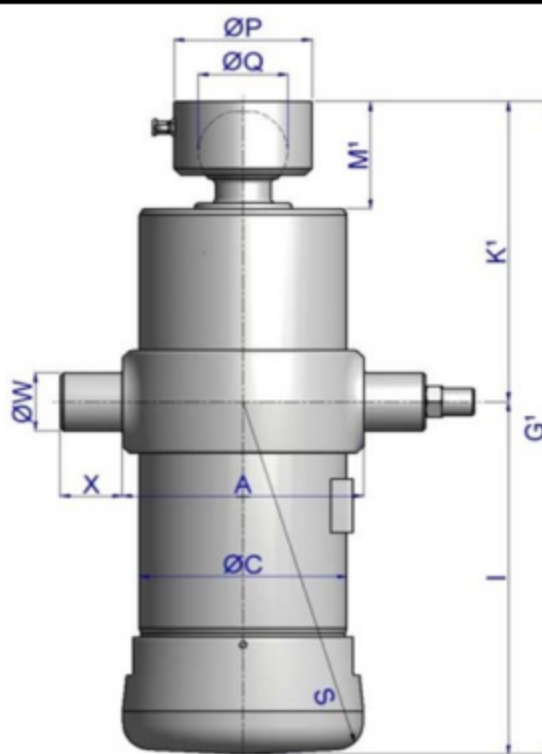

A	230
ØC	192
G ¹	739
I	481
K ¹	258
M ¹	99
ØP	100
ØQ	65
S	490
ØW	50
X	45

¹including 20 mm pull-out [tol. -5; +30 mm]

specifications

total stroke ¹	2980 mm
dry weight cylinder only	119 kg
total volume	39.4 L
working volume	36.3 L
maximum pressure	220 bar
maximum pump flow	61 l/min
maximum allowable thrust first stage ³	20.0 ton
oil inlet	3/4" BSP